



## INTERNATIONAL JOURNAL OF ENGINEERING SCIENCES & RESEARCH TECHNOLOGY

### Voltage Swell mitigation in Wind Farm System

Kadam D.P.<sup>\*1</sup>, Dr. Kushare B.E.<sup>2</sup>

<sup>\*1,2</sup> Department of Electrical K. K. Wagh Institute of Engineering Education and Research, Nashik (MS),  
India

[dpkadam@gmail.com](mailto:dpkadam@gmail.com)

#### Abstract

As the wind power penetration into the grid is increasing quickly, the influence of wind turbine on the power quality is becoming an important issue. Wind power penetration is the impact on power system stability. Power quality problems such as voltage sag and swell are some major concern. In this paper voltage swell issues is analyzed. Wind turbine connected to squirrel cage induction generator is modelled using PSCAD simulation software to analyse the said issues where STATCOM is introduced as an active voltage and reactive power supporter to increase the power system stability. STATCOM unit is developed to inject reactive power for mitigation of power quality problems and to get stable grid operation.

**Keywords:** Squirrel Cage Induction Generator (SCIG); PSCAD; Wind Turbine Generator (WTG); Static Synchronous Compensator (STATCOM); Power Quality.

#### Introduction

Wind power penetration is the impact on power system stability. To facilitate the investigation of the impact of a wind farm on the dynamics of the power system to which it is connected, an adequate model is required. In order to avoid the necessity of developing a detailed model of a wind farm with tens or hundreds of wind turbines and their interconnections, aggregated wind farm models are needed [1]. From each generating station the probability of the total generating capacity not exceeding a given power level. This gives a measure of the reliability of the system [2]. If the network is weak this situation will cause a voltage collapse to occur in the transmission system. The process can be dynamically supported by a STATCOM to improve voltage stability and to improve recovery from network faults and mitigate voltage flicker [3]. Frequently wind parks are connected to weak systems, as they are typically located far from major load centres and central generation. This reflects itself in the short circuit ratio (SCR) of the interconnection. For weak systems the SCR will usually be less than 6 having over speed of generator [4]. Reactive power is the most important aspect in today's condition. Reactive power consumption in a Wind farm is mainly due to the use of induction generators for energy conversion. The basic principle of induction generator is that they consume reactive power in order to generate real power. The magnetizing currents drawn by step up transformers

also contribute to reactive power consumption to some extent. This reactive power consumption leads to increased T & D losses, poor voltage profile over loading of T & D equipment and blocked capacity and over loading and reduction in life of T & D equipment [5]. Issue related to fixed speed wind turbine equipped with squirrel cage induction generators is the fault ride through capability. When connected to a weak power grid and during a grid fault, the over speeding of the wind turbines can cause voltage instability. As a result, utilities typically disconnect the wind turbines immediately from the grid when such a contingency occurs. With the rapid increase in penetration of wind power in power grids, tripping of many turbines in a large wind farm during grid faults may begin to influence the overall power system stability [6].

Today India is a major player in the global wind energy and as compared to develop countries Indian grid system is very weak also having poor infrastructure. Considering the increasing share of wind generation interfaced to grid it is necessary to study an overall prospective on various types of existing wind generator systems and possible generator configuration, critical power quality issues, problems related with grid connections [7]. Use of more intelligent controller for STATCOM and its interface to large power systems addressing various issues such as security, stability, and voltage profile improvement and power quality [8]. It was found that

STATCOM considerably improves the stability during and after disturbances especially when network is weak [9].

**Wind farm Modelling**

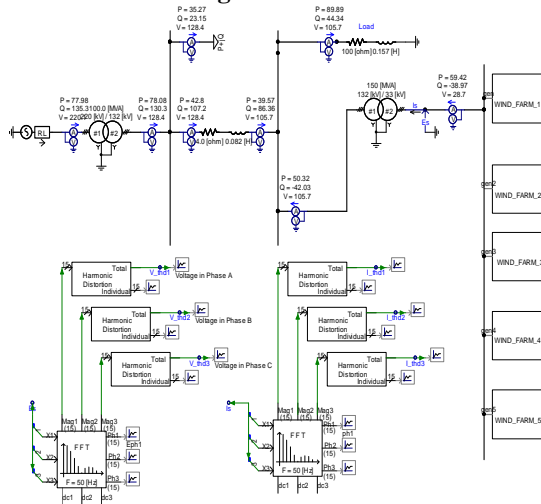

**Fig.1 Wind farm system**

A wind farm typically consists of a large number of individual wind turbine generators (WTGs) connected by an internal electrical network. To study the impact of wind farms on the dynamics of the power system, an important issue is to develop appropriate wind farm models to represent the dynamics of many individual WTGs. The major issues considered for the work for grid connected wind turbine generators (WTGs), equipped with squirrel cage induction generators (SCIGs) are sag/swell during three phase fault condition. The model is developed and compared by simulation studies in the PSCAD/EMTDC environment under different wind velocity and fluctuation conditions to obtain the reactive power burden on grid. Wind generators are primarily classified as fixed speed or variable speed. With most fixed speed units, the turbine drives an induction generator that is directly connected to the grid. For the studies carried out in this paper, it focuses on modeling the fixed speed unit. In this case study, large scale wind farm with squirrel cage induction generator having capacity 75 MW is connected to 33/132 kV substation to 220 kV electric grid system is modelled by PSCAD as shown in figure 1.

**Power Quality Issues**

Although the main issues of power quality are common to grid connected induction generator system are as voltage sag, swell.

**Voltage Swell**

Swell is an increase to between 1.1 and 1.8 p.u. rms voltage or current at the power frequency for

duration from 0.5 cycles to less than 1 minute. In this case study, voltage swell is developed due to symmetrical fault at different location. Voltage swell developed at generator, load & grid side due to faults are shown in figure 2.

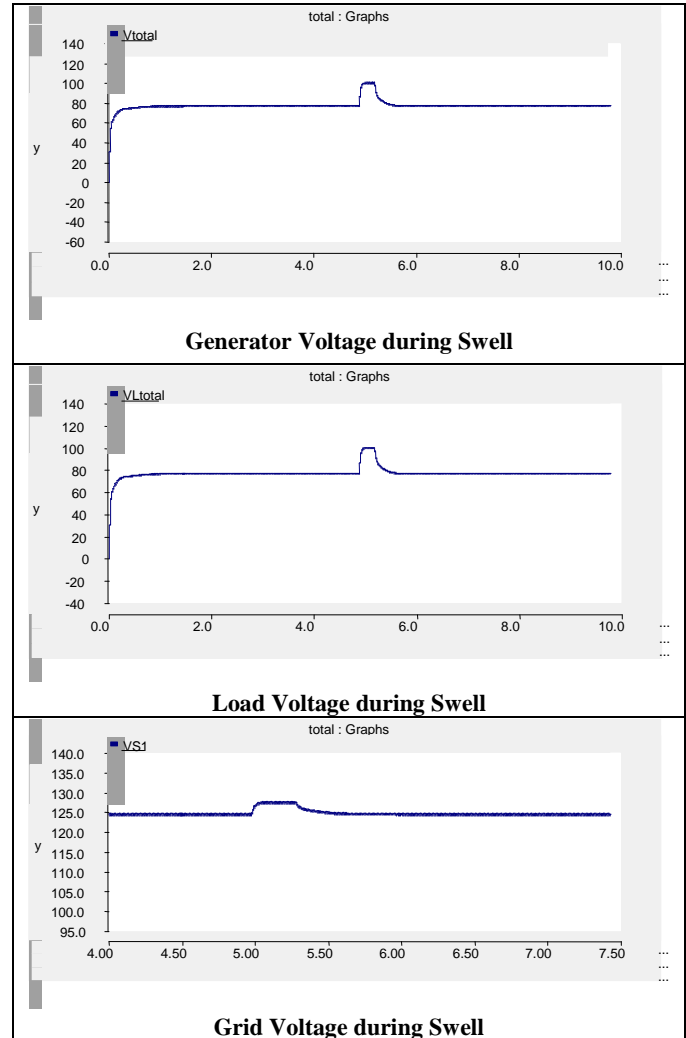

**Fig.2. Voltage Swell at different locations**

**Static Synchronous Compensator (STATCOM)**

The Static Synchronous Compensator (STATCOM) is a shunt connected reactive compensation equipment which is capable of generating and/or absorbing reactive power whose output can be varied so as to maintain control of specific parameters of the electric power system. It consists of VSC connected in shunt to a bus through a coupling transform. The objective of the STATCOM is to provide fast and smooth voltage regulation at the point of common coupling. In this paper, the VSC is modeled as a six-pulse IGBT

converter with a dc-link capacitor. The static compensators are devices with the ability to both generate and absorb reactive and active power, but the most common applications are in reactive power exchange between the AC system and the compensator. The compensator control is achieved by small variations in the switching angle of the semiconductor devices, so that the fundamental component of the voltage produced by the inverter is forced to lag or lead the AC system voltage by a few degrees. This causes active power to flow into or out of the inverter, modifying the value of the DC capacitor voltage, and consequently the magnitude of the inverter terminal voltage and the resultant reactive power. If the developed voltage is higher than system voltage the STATCOM will supply reactive power like a rotating synchronous compensator and improve the voltage and conversely if lower it will remove reactive power. Figure 3 indicates wind farm with SQIG connected to the grid with STATCOM is modelled.

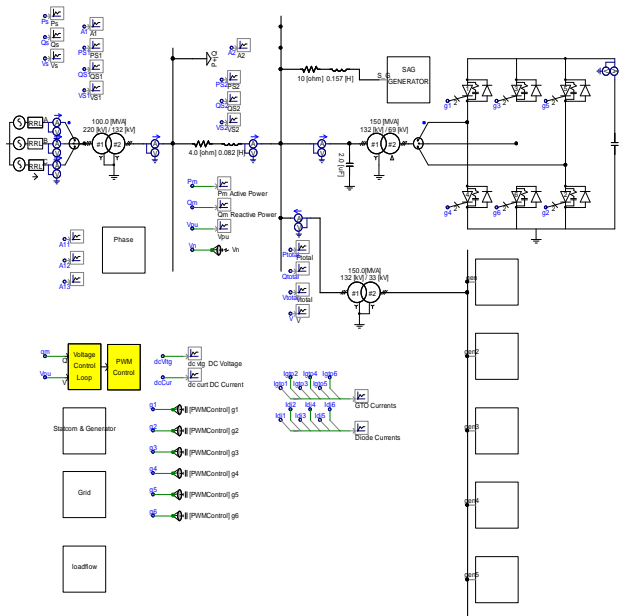

Fig.3. Wind farm connected by STATCOM.

**Voltage Swell Mitigation**

From the simulation results, the designed wind farm with STATCOM responded well in mitigating voltage swell caused by symmetrical fault which is shown in figure 4.

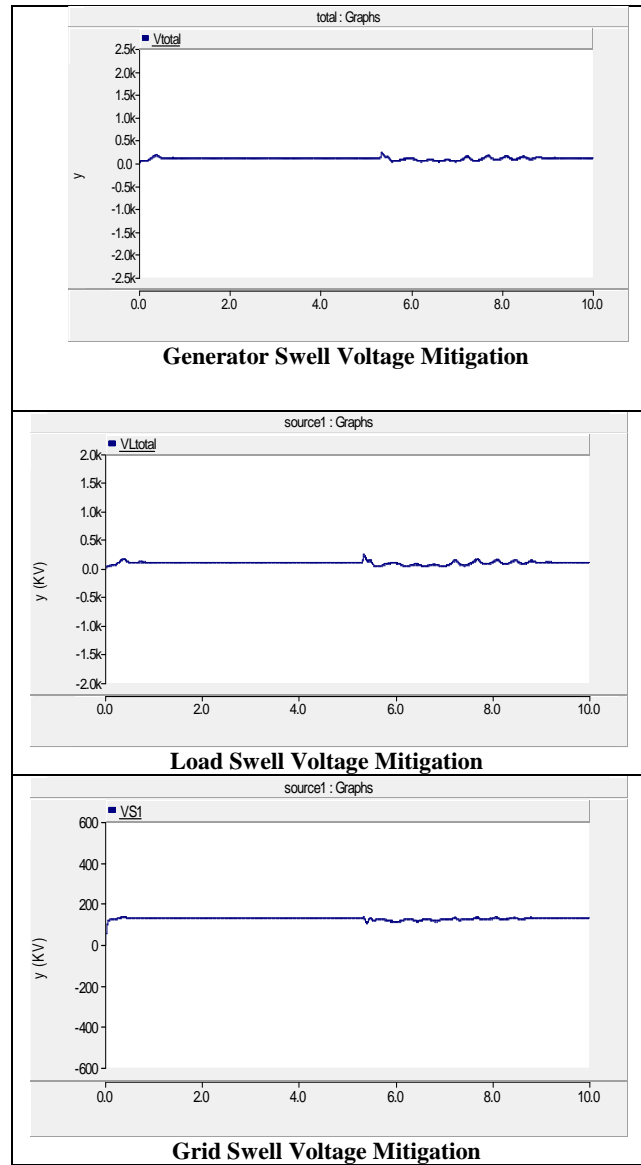

Fig.4. Voltage swells mitigation by STATCOM.

**Conclusion**

A simulation on model of wind farm is designed in PSCAD software to study the voltage swell mitigation using STATCOM. The study has demonstrated that an additional active voltage/var support produced by a STATCOM can significantly improve the recovery of wind turbines from fault since this device can make a faster restoration of the voltage, improving the stability limit conditions of the induction generators.

The simulation results provide a clear qualitative verification of transient margin increase in the wind energy conversion system with STATCOM when compared to the system without the STATCOM support.

### References

- [1] J. G. Slootweg and W. L. Kling, "Modelling of Large Wind Farms in Power System Simulations", Paper published in IEEE Conference, PP. 503-508, 2002.
- [2] J. Bhagwan Reddy, D. N. Reddy, "Reliability Evaluation of a Grid Connected Wind Farm-A case Study of Ramgiri Wind farm in Andhra Pradesh, India", Paper published in IEEE Conference, PP. 659-662, 2004.
- [3] R. Grunbaum, P. Halvarsson, D. Larsson, P. R. Jones, "Conditioning of Power Grids serving Offshore Wind Farms based on Asynchronous Generators", ABB Power Technologies, Sweden, PP. 34-39, 2004.
- [4] Mazen Abdel- Salam, Adel Ahmed Mahmoud Mahrous, "Steady- state and transient analyses of wind farm connected to an electric grid with varying stiffness", Proceedings of the 14th International Middle East Power Systems Conference, Cairo University, Egypt, Dec. 19-21, 2010 PP. 203-208, 2010.
- [5] R. Venkatesh, "Power Quality issues and Grid interfacing of wind Electric Generators and Design of an Optimal reactive Power Compensation System for Wind farms"
- [6] Kadam D. P. and Dr. Kushare B. E. "Dynamic Behaviour of Large Scale Wind Farm", International Journal of Electrical Engineering, Volume 5, Number 6, PP. 757-764, 2012.
- [7] Kadam D. P. and Dr. Kushare B. E. "Overview of Different Wind generator Systems and their comparisons", International Journal of Engineering Science & Advanced Technology, Volume 2, Issue-4, PP. 1076-1081, 2012.
- [8] S. M. Muyeen, Mohammad Abdul Mannan, Mohd. Hasan Ali, Rion Takahashi, Toshiaki Murata, Junji Tamura, "Stabilization of Grid Connected Wind Generator by STATCOM", Paper published in IEEE PEDS 2005 Conference, PP. 1584-1588, 2005.
- [9] Lie Xu, Yao and Christian Sasse, "Comparison of Using SVC and STATCOM for Wind Farm Integration", IEEE Proceedings of the International conference on Power System Technology, PP. 1-7, 2006.